

TYPE "A" CUT REPAIR DETAIL
COUNTY ASPHALT ROADS

N.T.S.

NOTE:
 BACKFILL TO BE PLACED AT 4-12" LAYERS, AND TAMPED PROPERLY, IN ACCORDANCE WITH AWWA C600 (LATEST REVISION)

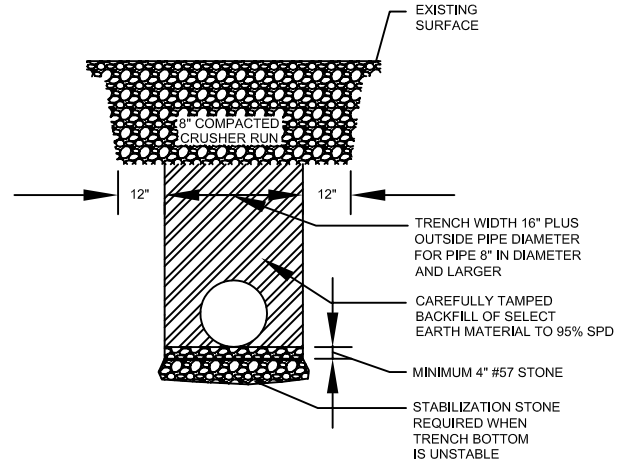

TYPE "B" CUT REPAIR DETAIL
DIRT OR GRAVEL ROADS

N.T.S.

NOTE:
 BACKFILL TO BE PLACED AT 4-12" LAYERS, AND TAMPED PROPERLY, IN ACCORDANCE WITH AWWA C600 (LATEST REVISION)

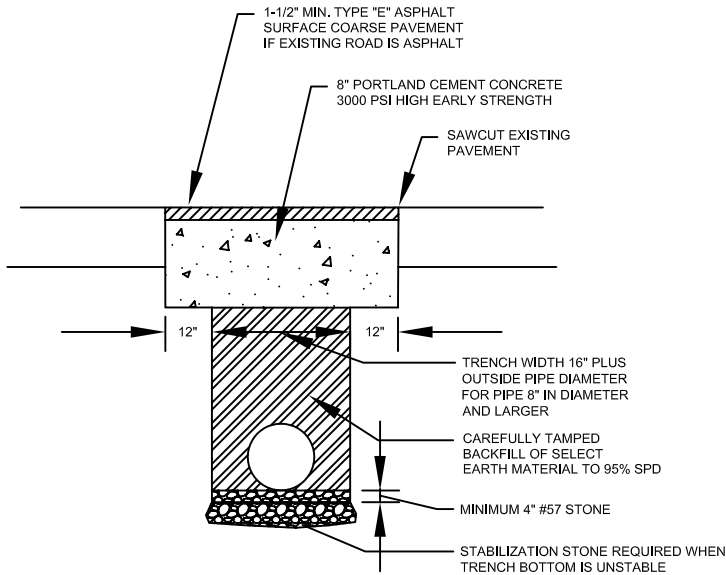

TYPE "C" CUT REPAIR DETAIL
CONCRETE ROADS AND DOT ASPHALT ROADS

N.T.S.

NOTE:
 BACKFILL TO BE PLACED AT 4-12" LAYERS, AND TAMPED PROPERLY, IN ACCORDANCE WITH AWWA C600 (LATEST REVISION)

NOTES:

1. ALL MATERIALS AND METHODS OF INSTALLATION SHALL COMPLY WITH THE GA D.O.T.'S "STANDARD SPECIFICATIONS FOR ROAD AND BRIDGE CONSTRUCTION", 1993 EDITION, OR LATEST REVISION THERETO.
2. FOR TYPE "C", THE POURED CONCRETE SHALL BE COVERED WITH STEEL PLATES A MINIMUM OF 24-HOURS TO ALLOW ADEQUATE SET-UP.
3. TRAFFIC CONTROL PLAN MUST BE APPROVED BY THE AUTHORITY HAVING JURISDICTION BEFORE WORK BEGINS.
4. FINAL APPROVAL OF PAVEMENT CUT REPAIRS RESIDES WITH THE AUTHORITY HAVING JURISDICTION.

REVISIONS

City of Cumming
 Department of Utilities - Distribution and Collection Division



PAVEMENT CUT REPAIRS
TYPE "A", "B", & "C"

S-17