

PLAN VIEW

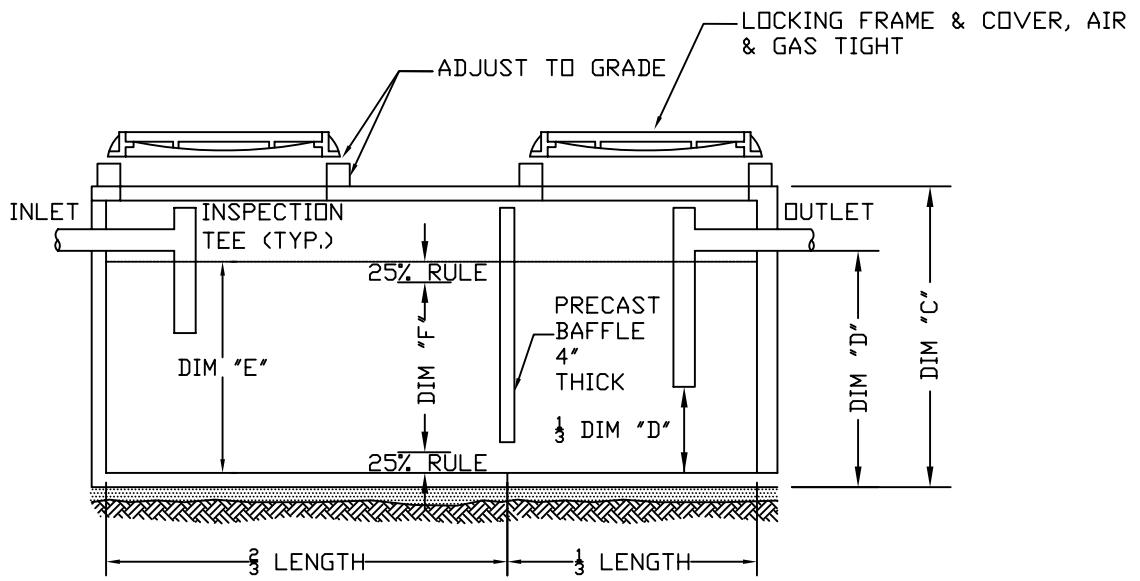

SIZING CHART

GALLON CAPACITY	DIM "A"	DIM "B"	DIM "C"	DIM "D"	DIM "E"
1000	9'-0"	4'-8"	7'-2"	4'-4"	4'-0"

NOTES:

THE 25% RULE REQUIRES THAT THE DEPTH OF OIL AND GREASE FLOATING AND SETTLED (DIMENSIONS "F" & "G") SHALL NOT BE EQUAL TO OR GREATER THAN 25% OF THE TOTAL OPERATING DEPTH OF THE TRAP.

N.T.S.

REVISIONS

City of Cumming
 Department of Utilities - Distribution and Collection Division



TYPICAL GREASE INTERCEPTOR

S-23